

Part Number: PT18A-34090

Kit Contents

Item #	Quantity Reqd.	Description
1	1	Stainless Steel Exhaust Tip
2	1	Stainless Steel Clamp Assembly
3	1	Aluminum Bushing
4	1	Installation Instructions

Hardware Bag Contents

Item #	Quantity Reqd.	Description
None		

Additional Items Required For Installation

Item #	Quantity Reqd.	Description
None		

Conflicts

--

Recommended Tools

Personal & Vehicle Protection	Notes
None	
Special Tools	Notes
None	
Installation Tools	Notes
Installation Tools	
Ratchet	
Socket	15 mm Deep Well Socket
Torque Wrench	55 N-m
Rubber Mallet	
Non-scratch Cloth	
Wiping Cloth	
Special Chemicals	
Glass Cleaner Approved Cleaner	Dealer Installed VDC Installed

General Applicability

--

Recommended Sequence of Application

Item #	Accessory
1	Exhaust Tip

*Mandatory

Vehicle Service Parts (may be required for reassembly)

Item #	Quantity Reqd.	Description
1		
2		
3		

Legend

 **STOP:** Damage to the vehicle may occur. Do not proceed until process has been complied with.

 **OPERATOR SAFETY:** Use caution to avoid risk of injury.

 **CAUTION:** A process that must be carefully observed in order to reduce the risk of damage to the accessory/vehicle and to ensure a quality installation.

 **TOOLS & EQUIPMENT:** Used in Figures calls out the specific tools and equipment recommended for this process.

 **REVISION MARK:** This mark highlights a change in installation with respect to previous issue.

 **SAFETY TORQUE:** This mark indicates that torque is related to safety.



Procedure

Care must be taken when installing this accessory to ensure damage does not occur to the vehicle. The installation of this accessory should follow approved guidelines to ensure a quality installation.

These guidelines can be found in the "Accessory Installation Practices" document.

This document covers such items as:-

- Vehicle Protection (use of covers and blankets, cleaning chemicals, etc.).
- Safety (eye protection, rechecking torque procedure, etc.).
- Vehicle Disassembly/Reassembly (panel removal, part storage, etc.).
- Electrical Component Disassembly/Reassembly (battery disconnection, connector removal, etc.).

Please see your Toyota dealer for a copy of this document.

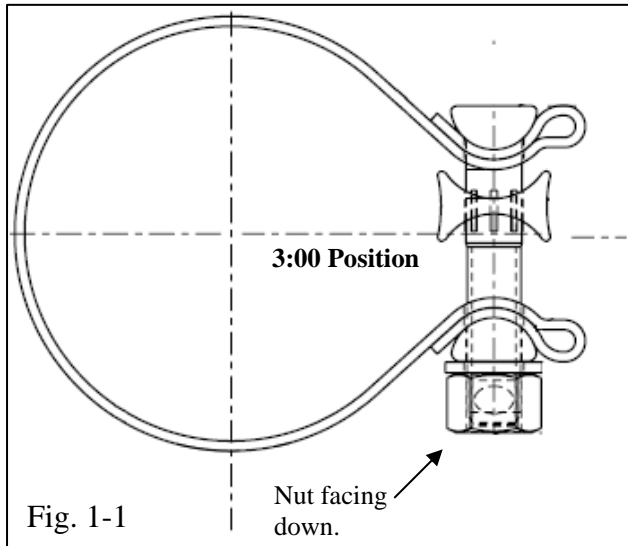

1. Installation.

- (a) Make sure the vehicle's tail pipe is free from dirt and debris.
- (b) Remove exhaust tip from box and set on a soft surface to prevent scratching.

- (c) Slide the Stainless Steel clamp over the vehicle tailpipe as shown. (Fig 1-1 & 1-2)



- (1) Locate the bolt of the clamp at the right side with the nut facing down as shown. (Fig 1-1 & 1-2)

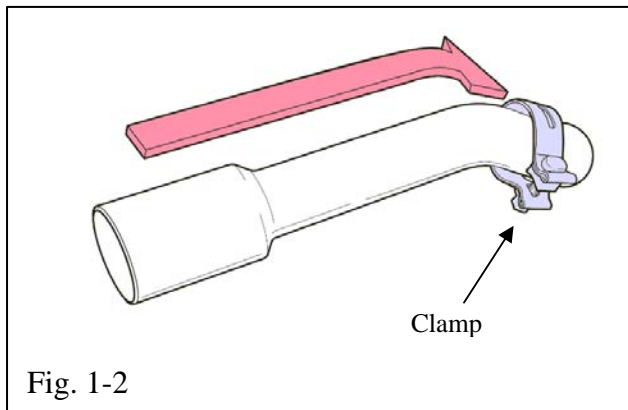

- (d) Slide the exhaust tip over the tail pipe with the bump at 12:00 position as shown. (Fig 1-3)

- (1) If necessary, a rubber mallet may be used to aid installation.



- (2) Continue sliding the exhaust tip over the tail pipe until there is approximately a 25 mm distance between the end of the tail pipe and the end of the exhaust tip as shown. (Fig. 1-3)

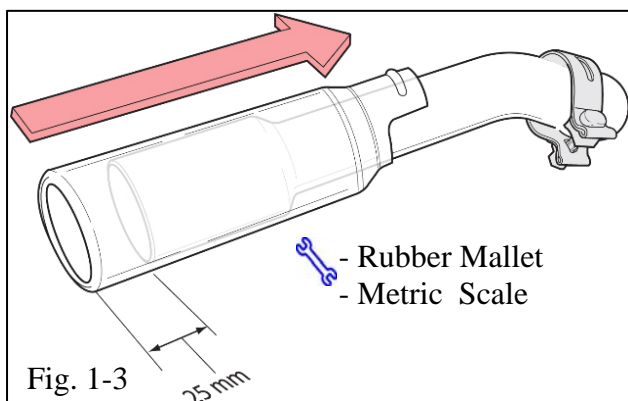

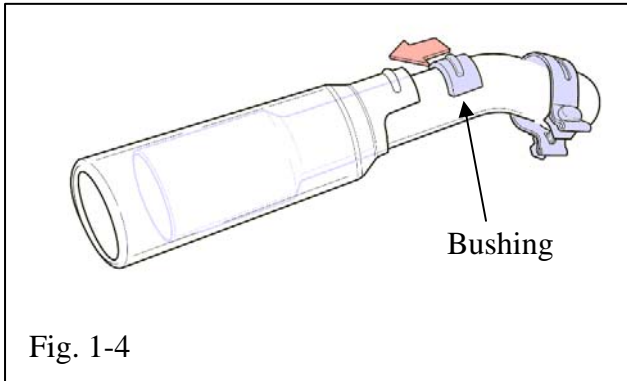

(e) Insert bushing and position the clamp:
(Fig. 1-4 & 1-5)

(1) Insert the bushing by aligning the bump on the bushing with the bump stamped into the exhaust tip as shown. (Fig. 1-4)



(2) Slide the clamp over the exhaust tip and position the clamp so that the slot on the clamp is positioned over the exhaust tip "bump". (Fig. 1-5)

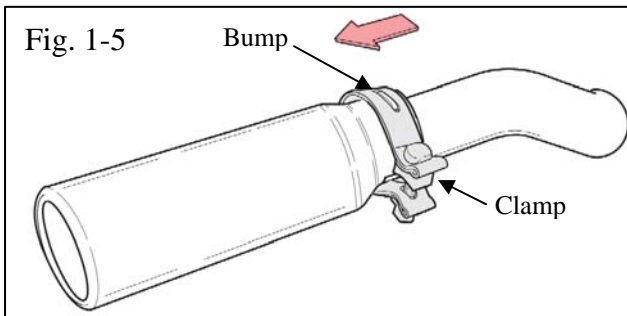

(f) Once the tip is positioned correctly and the alignment seems accurate, tighten the clamp nut making sure the clamp remains in the proper position (Figs.1-5 & 1-6)



NOTE: Make sure the slot on the clamp is positioned over the bump on the exhaust tip before final torque. (Fig. 1-6)

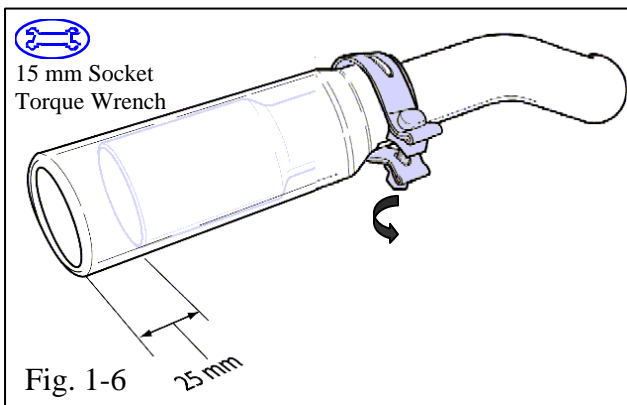

(g) Torque clamp nut to 55 N-m (40.5 ft-lbf).



Torque: 55 Nm (40.5 ft-lbf)

(h) Clean exhaust tip with glass cleaner or approved cleaner and non-scratching cloth.

TOYOTA TUNDRA 2003 - STAINLESS STEEL EXHAUST TIP

Checklist - these points **MUST** be checked to ensure a quality installation.

<u>Check:</u>	<u>Look For:</u>
<p><u>Accessory Function Checks</u></p> <p><input type="checkbox"/> Correct part number has been installed.</p> <p><input type="checkbox"/> Clamp Alignment</p> <p><input type="checkbox"/> Tip Position</p>	<p>Verify part number on package.</p> <p>Clamp should be oriented with bolt on the right side with the nut facing down. Slot should be on top over the bump.</p> <p>Tip should be positioned with the bump on top @ 12:00.</p> <p>There should be approximately a 25 mm distance between the end of the tail pipe and the end of the exhaust tip.</p>
<p><u>Vehicle Function Checks</u></p> <p><input type="checkbox"/> Rattle or vibration</p>	<p>Start engine and check for rattle or vibration of exhaust tip.</p>
<p><u>Vehicle Appearance Check</u></p> <p><input type="checkbox"/> After accessory installation and removal of protective cover(s), perform a visual inspection.</p>	<p>Ensure no damage (including scuffs and scratches) was caused during the installation process. (For PPO installations, refer to TMS Accessory Quality Shipping Standard.)</p>